

Type : 3ED200L2D-FA-BA-000

Date : 01.01.2023

Power [kW]	: 45.0	Efficiency Class	: IE3
Input Voltage [V]	: 400	Duty Cycle	: S1
Connection Type [Δ / Y]	: Δ	Service Factor	: --
Frequency [Hz]	: 50	Frame Size	: 200L
Pole Number	: 2	Weight [kg]	: 275
Nominal Speed [rpm]	: 2970	Insulation Class	: F [155°C]
Nominal Current [A]	: 78.1	Temperature Rise	: B [80°K]
Nominal Moment [Nm]	: 145	Protection Class	: IP55
Nominal Efficiency [η]	: 94.0	Vibration Severity Grade	: A
Power Factor [cosφ]	: 0.89	Method of Cooling	: IC411 (TEFC)
Locked Rotor Current [Ia/In]	: 9.0	Direction of Rotation	: Bidirectional
Locked Rotor Torque [Ma/Mn]	: 3.6	Balance	: Half Key
Breakdown Torque [Mk/Mn]	: 3.5	Motor Thermal Protection	: PTC
Motor Color	: RAL 7031	Altitude Above Sea Level	: 1000m
Ambient Temperature	: -15°C / +40°C	Sound Pressure Level [dBA]	: 77

### ELECTRICAL DATA

Δ / Y	U [V]	f [Hz]	P [kW]	n [rpm]	I [A]	η [%100]	η [%75]	η [%50]	Cosφ	Cl
Δ	400	50	45.0	2970	78.1	94.0	94.9	94.7	0.89	IE3
Y	690	50	45.0	2970	45.1	94.0	94.9	94.7	0.89	IE3
Δ	460	60	45.0	3585	68.2	93.6	93.5	93.2	0.89	IE3
Δ	460	60	52.2	3565	77.9	93.6	93.7	93.3	0.90	IE3

### MECHANICAL DATA

Moment of Inertia [kgm <sup>2</sup> ]	: 0.18700
Bearing [DS / NS]	: 6312ZZ / 6212ZZ
Frame Material	: Cast Iron
Flange Type / Material	: B5 / Cast Iron
Cooling Fan Material	: Plastic
End Shield Material	: Cast Iron

### TERMINAL BOX

Terminal Box Material	: Cast Iron
Terminal Box Position	: Top
Terminal Box Cable Entry	: 2xM40x1.5
Terminal Box Blind Cap	: --
Contact Screw Thread	: M6

### MECHANICAL DIMENSIONS

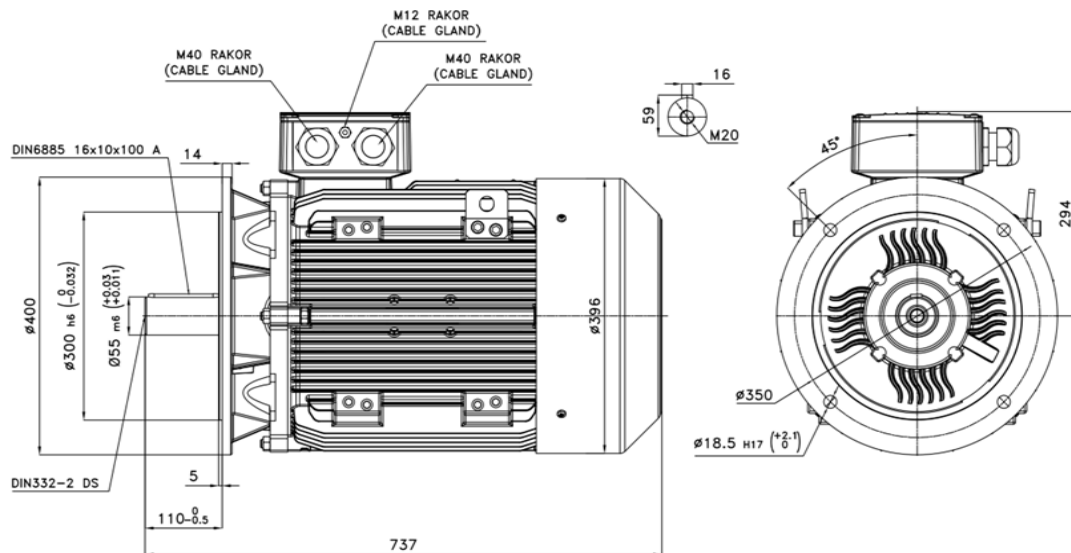

Manufactured and tested in accordance with IEC 60034

\*Technical data are subject to change! There may be discrepancies between calculated and rating plate values.

\*ELK Motor has right to change all the data without prior notice.

FR.AG.010 REV.NO: 04 REV.DATE: 01.01.2023



ELK MOTOR SAN. ve TİC. A.Ş.  
www.elkmotor.com.tr  
+90 (282) 726 92 94

## TECHNICAL DATASHEET ACCORDING TO COMMISSION REGULATION (EU) 2019/1781 THREE PHASE INDUCTION MOTOR - SQUIRREL CAGE

Type : 3ED200L2D-FA-BA-000

Date : 01.01.2023

### NAMEPLATE DATA

Power [kW]	: 45.0	Nominal Speed [rpm]	: 2970
Nominal Voltage [V]	: 400	Nominal Current [A]	: 78.1
Connection Type [ $\Delta$ / Y]	: $\Delta$	Nominal Moment [Nm]	: 145
Nominal Frequency [Hz]	: 50	Nominal Efficiency [ $\eta$ %]	: 94.0

### THE POWER LOSSES AT SEVEN OPERATING POINTS ACCORDING TO COMMISSION REGULATION (EU) 2019/1781

Operating Point Number	Speed $n/n_N$ [%]	Torque $T/T_N$ [%]	Relative Power Losses $P_L/P_N$ [%]	Efficiency $\eta$ [%]
P <sub>1</sub>	90	100	5.6	94.1
P <sub>2</sub>	50	100	4.0	92.7
P <sub>3</sub>	25	100	3.3	88.3
P <sub>4</sub>	90	50	3.7	92.5
P <sub>5</sub>	50	50	2.0	92.6
P <sub>6</sub>	50	25	1.5	89.3
P <sub>7</sub>	25	25	0.8	88.8

### MAP OF RELATIVE POWER LOSSES $P_L/P_N$ [%]

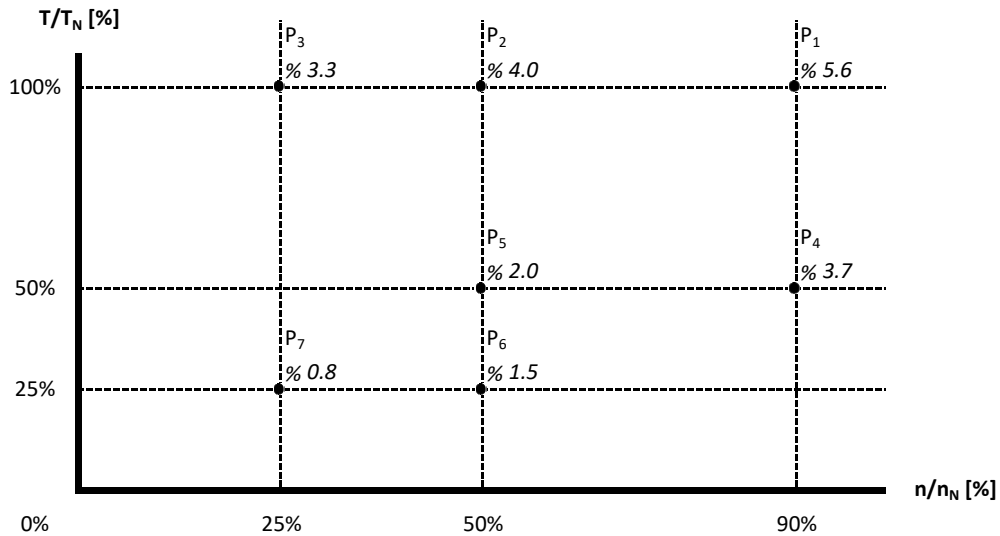

Manufactured and tested in accordance with IEC 60034

FR.AG.010 REV.NO: 04 REV.DATE: 01.01.2023

\*Technical data are subject to change! There may be discrepancies between calculated and rating plate values.

\*ELK Motor has right to change all the data without prior notice.

Motor Code : 3ED200L2D-FA-BA-000

### Torque and Current Curves Related to Speed

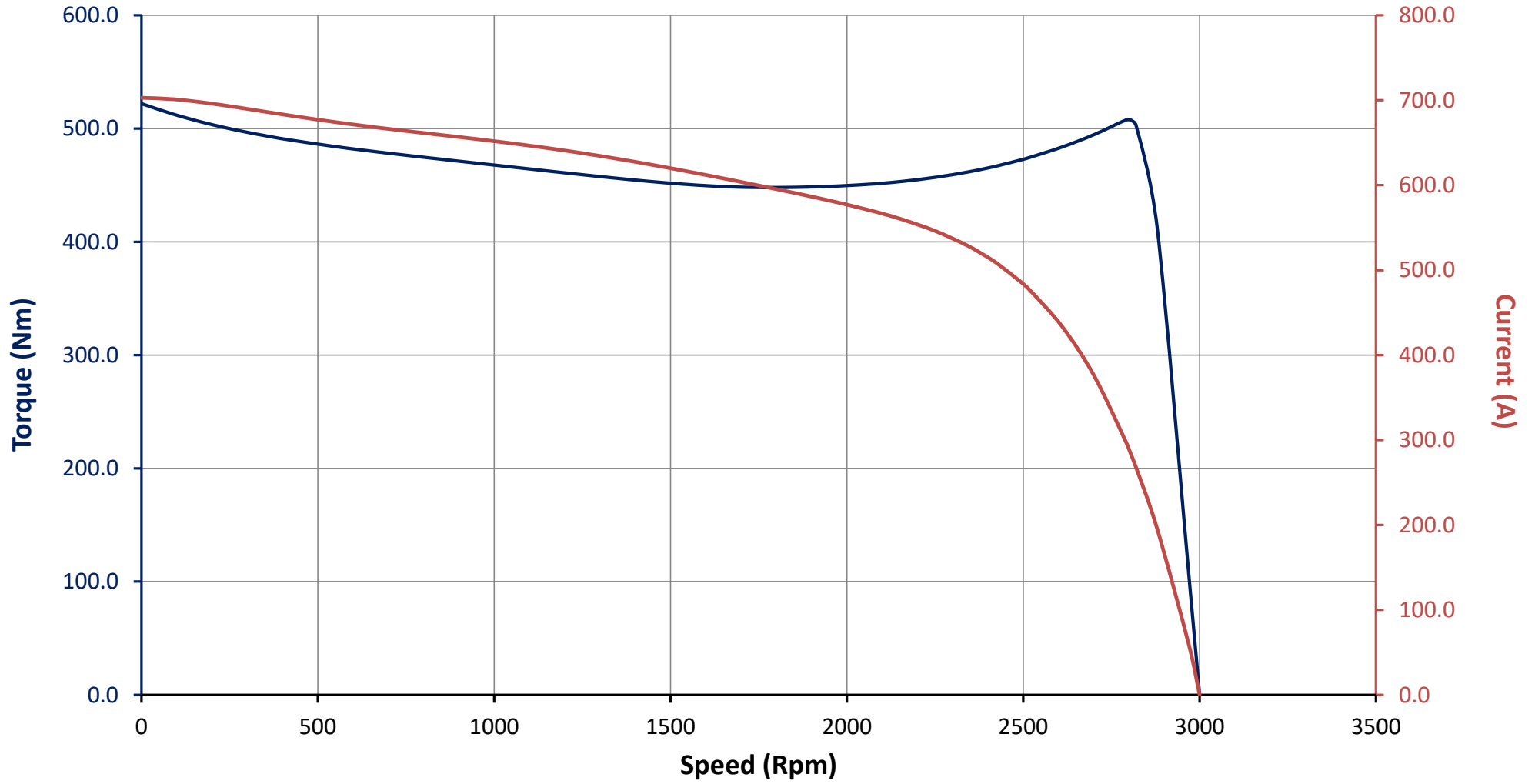

Motor Code : 3ED200L2D-FA-BA-000

### Performance Curves Related to Rated Output

