

Type : 3EL090S4C-PA-A0-000**Date** : 01.01.2023

Power [kW]	: 1.10	Efficiency Class	: IE3
Input Voltage [V]	: 400	Duty Cycle	: S1
Connection Type [Δ / Y]	: Y	Service Factor	: 1.20
Frequency [Hz]	: 50	Frame Size	: 090S
Pole Number	: 4	Weight [kg]	: 16.3
Nominal Speed [rpm]	: 1450	Insulation Class	: F [155°C]
Nominal Current [A]	: 2.51	Temperature Rise	: B [80°K]
Nominal Moment [Nm]	: 7.25	Protection Class	: IP55
Nominal Efficiency [η]	: 84.5	Vibration Severity Grade	: A
Power Factor [$\cos\phi$]	: 0.75	Method of Cooling	: IC411 (TEFC)
Locked Rotor Current [I_a/I_n]	: 7.0	Direction of Rotation	: Bidirectional
Locked Rotor Torque [M_a/M_n]	: 2.6	Balance	: Half Key
Breakdown Torque [M_k/M_n]	: 3.4	Motor Thermal Protection	: --
Motor Color	: RAL 7031	Altitude Above Sea Level	: 1000m
Ambient Temperature	: -15°C / +40°C	Sound Pressure Level [dBA]	: 51

ELECTRICAL DATA

Δ / Y	U [V]	f [Hz]	P [kW]	n [rpm]	I [A]	η [%100]	η [%75]	η [%50]	Cos ϕ	Cl
Δ	230	50	1.10	1450	4.35	84.5	84.3	82.0	0.75	IE3
Y	400	50	1.10	1450	2.51	84.5	84.3	82.0	0.75	IE3
Y	460	60	1.10	1755	2.19	86.5	86.7	84.8	0.73	IE3
Y	460	60	1.28	1760	2.44	86.5	86.8	85.0	0.76	IE3

MECHANICAL DATA

Moment of Inertia [kgm^2]	: 0.00355
Bearing [DS / NS]	: 6205ZZ / 6205ZZ
Frame Material	: Aluminum
Flange Type / Material	: B5 / Aluminum
Cooling Fan Material	: Plastic
End Shield Material	: Aluminum

TERMINAL BOX

Terminal Box Material	: Aluminum
Terminal Box Position	: Top
Terminal Box Cable Entry	: M20x1.5
Terminal Box Blind Cap	: M16x1.5
Contact Screw Thread	: M4

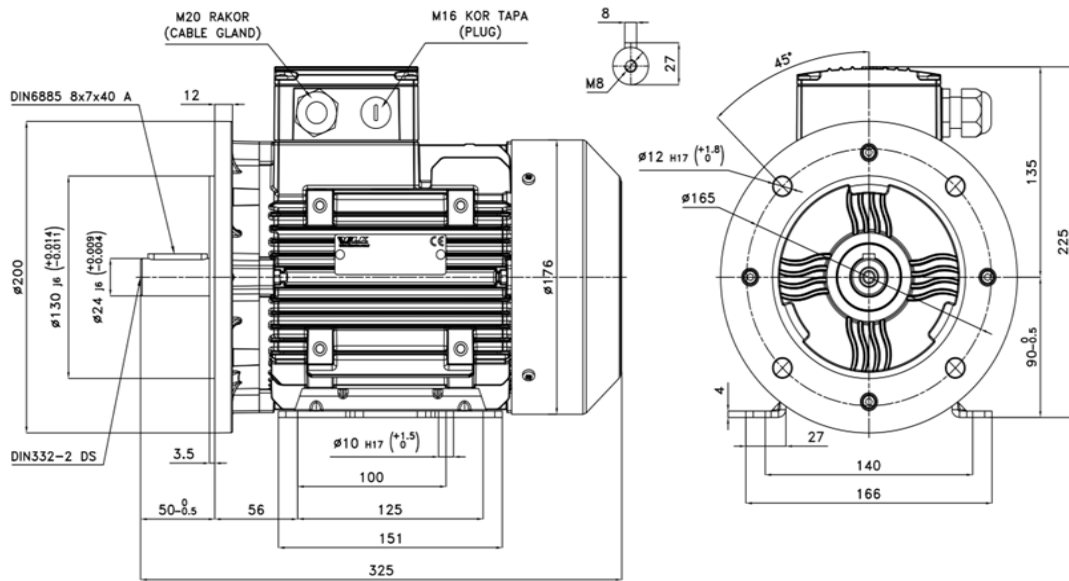
MECHANICAL DIMENSIONS

Manufactured and tested in accordance with IEC 60034

*Technical data are subject to change! There may be discrepancies between calculated and rating plate values.

*ELK Motor has right to change all the data without prior notice.

FR.AG.010 REV.NO: 04 REV.DATE: 01.01.2023



ELK MOTOR SAN. ve TİC. A.Ş.
www.elkmotor.com.tr
+90 (282) 726 92 94

TECHNICAL DATASHEET ACCORDING TO COMMISSION REGULATION (EU) 2019/1781 THREE PHASE INDUCTION MOTOR - SQUIRREL CAGE

Type : 3EL090S4C-PA-A0-000

Date : 01.01.2023

NAMEPLATE DATA

Power [kW]	: 1.10	Nominal Speed [rpm]	: 1450
Nominal Voltage [V]	: 400	Nominal Current [A]	: 2.51
Connection Type [Δ / Y]	: Y	Nominal Moment [Nm]	: 7.25
Nominal Frequency [Hz]	: 50	Nominal Efficiency [η %]	: 84.5

THE POWER LOSSES AT SEVEN OPERATING POINTS ACCORDING TO COMMISSION REGULATION (EU) 2019/1781

Operating Point Number	Speed n/n_N [%]	Torque T/T_N [%]	Relative Power Losses P_L/P_N [%]	Efficiency η [%]
P ₁	90	100	19.8	82.0
P ₂	50	100	16.0	75.7
P ₃	25	100	15.4	61.9
P ₄	90	50	10.7	80.8
P ₅	50	50	8.1	75.5
P ₆	50	25	6.7	65.3
P ₇	25	25	4.5	58.2

MAP OF RELATIVE POWER LOSSES P_L/P_N [%]

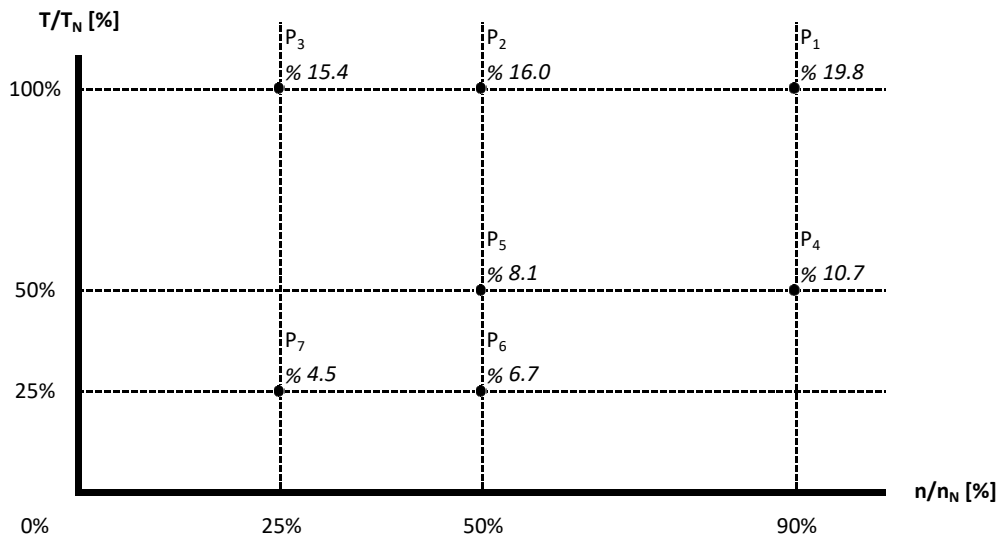

Manufactured and tested in accordance with IEC 60034

FR.AG.010 REV.NO: 04 REV.DATE: 01.01.2023

*Technical data are subject to change! There may be discrepancies between calculated and rating plate values.

*ELK Motor has right to change all the data without prior notice.

Motor Code : 3EL090S4C-PA-A0-000

Torque and Current Curves Related to Speed

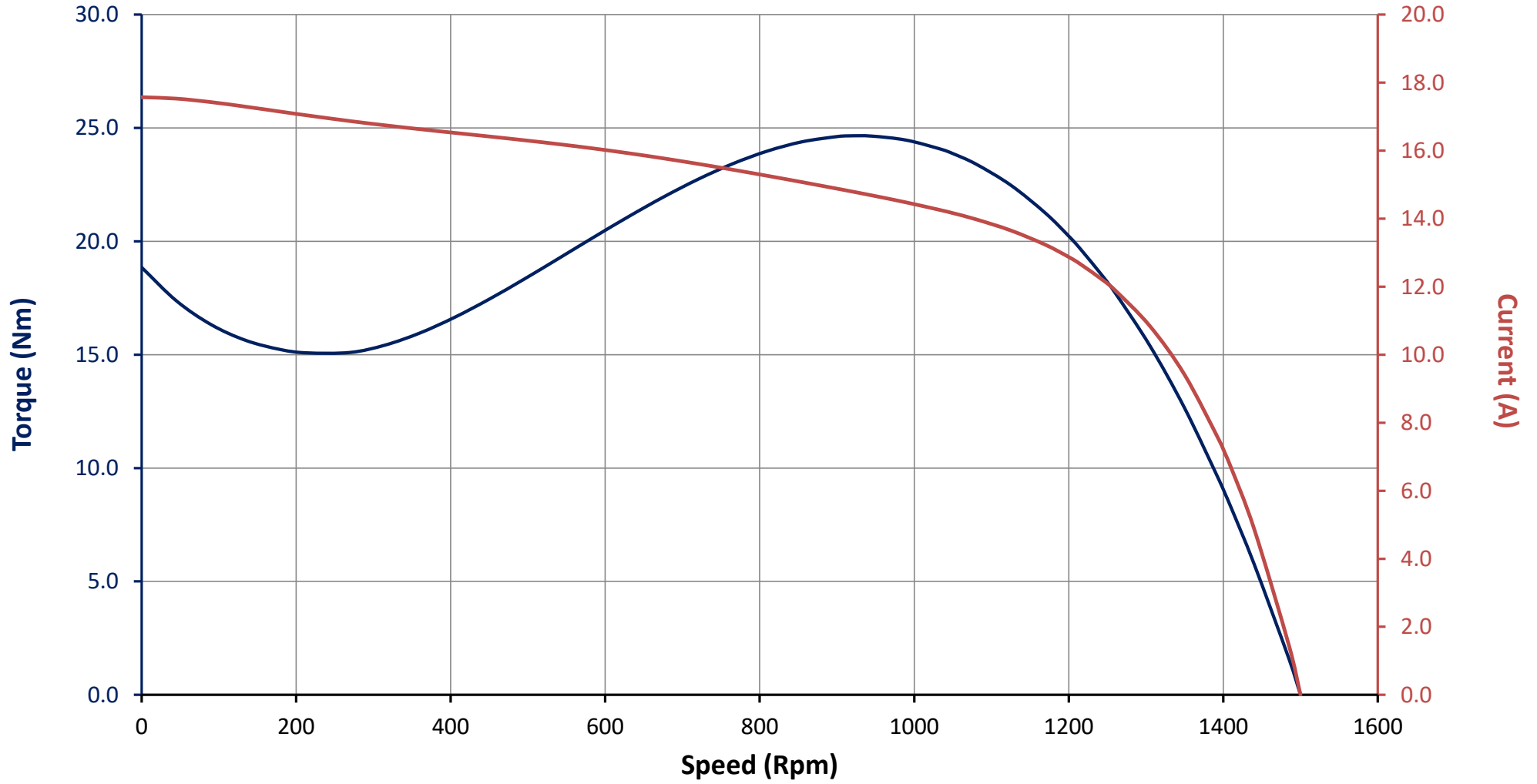

Motor Code : 3EL090S4C-PA-A0-000

Performance Curves Related to Rated Output

