

**Type** : 3EL160M4C-FA-BA-000**Date** : 01.01.2023

Power [kW]	: 11.0	Efficiency Class	: IE3
Input Voltage [V]	: 400	Duty Cycle	: S1
Connection Type [ $\Delta$ / Y]	: $\Delta$	Service Factor	: 1.20
Frequency [Hz]	: 50	Frame Size	: 160M
Pole Number	: 4	Weight [kg]	: 89.2
Nominal Speed [rpm]	: 1465	Insulation Class	: F [155°C]
Nominal Current [A]	: 21.0	Temperature Rise	: B [80°K]
Nominal Moment [Nm]	: 71.7	Protection Class	: IP55
Nominal Efficiency [ $\eta$ ]	: 91.5	Vibration Severity Grade	: A
Power Factor [ $\cos\phi$ ]	: 0.83	Method of Cooling	: IC411 (TEFC)
Locked Rotor Current [ $I_a/I_n$ ]	: 7.6	Direction of Rotation	: Bidirectional
Locked Rotor Torque [ $M_a/M_n$ ]	: 2.8	Balance	: Half Key
Breakdown Torque [ $M_k/M_n$ ]	: 3.3	Motor Thermal Protection	: PTC
Motor Color	: RAL 7031	Altitude Above Sea Level	: 1000m
Ambient Temperature	: -15°C / +40°C	Sound Pressure Level [dBA]	: 63

**ELECTRICAL DATA**

$\Delta$ / Y	U [V]	f [Hz]	P [kW]	n [rpm]	I [A]	$\eta$ [%100]	$\eta$ [%75]	$\eta$ [%50]	Cos $\phi$	Cl
$\Delta$	400	50	11.0	1465	21.0	91.5	92.1	91.7	0.83	IE3
Y	690	50	11.0	1465	12.1	91.5	92.1	91.7	0.83	IE3
$\Delta$	460	60	11.0	1770	18.2	92.4	92.8	92.1	0.82	IE3
$\Delta$	460	60	12.8	1760	20.6	92.4	92.6	91.2	0.84	IE3

**MECHANICAL DATA**

Moment of Inertia [kgm <sup>2</sup> ]	: 0.07011
Bearing [DS / NS]	: 6309ZZ / 6209ZZ
Frame Material	: Aluminum
Flange Type / Material	: B5 / Aluminum
Cooling Fan Material	: Plastic
End Shield Material	: Aluminum

**TERMINAL BOX**

Terminal Box Material	: Aluminum
Terminal Box Position	: Top
Terminal Box Cable Entry	: 2xM32x1.5
Terminal Box Blind Cap	: --
Contact Screw Thread	: M6

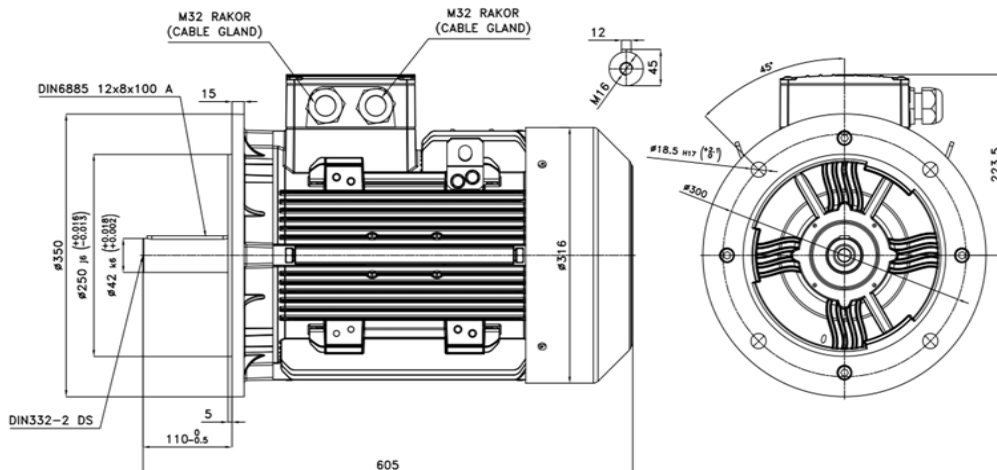
**MECHANICAL DIMENSIONS**

Manufactured and tested in accordance with IEC 60034

\*Technical data are subject to change! There may be discrepancies between calculated and rating plate values.

\*ELK Motor has right to change all the data without prior notice.

FR.AG.010 REV.NO: 04 REV.DATE: 01.01.2023



ELK MOTOR SAN. ve TİC. A.Ş.  
www.elkmotor.com.tr  
+90 (282) 726 92 94

## TECHNICAL DATASHEET ACCORDING TO COMMISSION REGULATION (EU) 2019/1781 THREE PHASE INDUCTION MOTOR - SQUIRREL CAGE

Type : 3EL160M4C-FA-BA-000

Date : 01.01.2023

### NAMEPLATE DATA

Power [kW]	: 11.0	Nominal Speed [rpm]	: 1465
Nominal Voltage [V]	: 400	Nominal Current [A]	: 21.0
Connection Type [ $\Delta$ / Y]	: $\Delta$	Nominal Moment [Nm]	: 71.7
Nominal Frequency [Hz]	: 50	Nominal Efficiency [ $\eta$ %]	: 91.5

### THE POWER LOSSES AT SEVEN OPERATING POINTS ACCORDING TO COMMISSION REGULATION (EU) 2019/1781

Operating Point Number	Speed $n/n_N$ [%]	Torque $T/T_N$ [%]	Relative Power Losses $P_L/P_N$ [%]	Efficiency $\eta$ [%]
P <sub>1</sub>	90	100	9.2	90.7
P <sub>2</sub>	50	100	7.1	87.6
P <sub>3</sub>	25	100	6.7	78.8
P <sub>4</sub>	90	50	5.6	89.0
P <sub>5</sub>	50	50	3.3	88.2
P <sub>6</sub>	50	25	2.4	83.9
P <sub>7</sub>	25	25	1.4	81.2

### MAP OF RELATIVE POWER LOSSES $P_L/P_N$ [%]

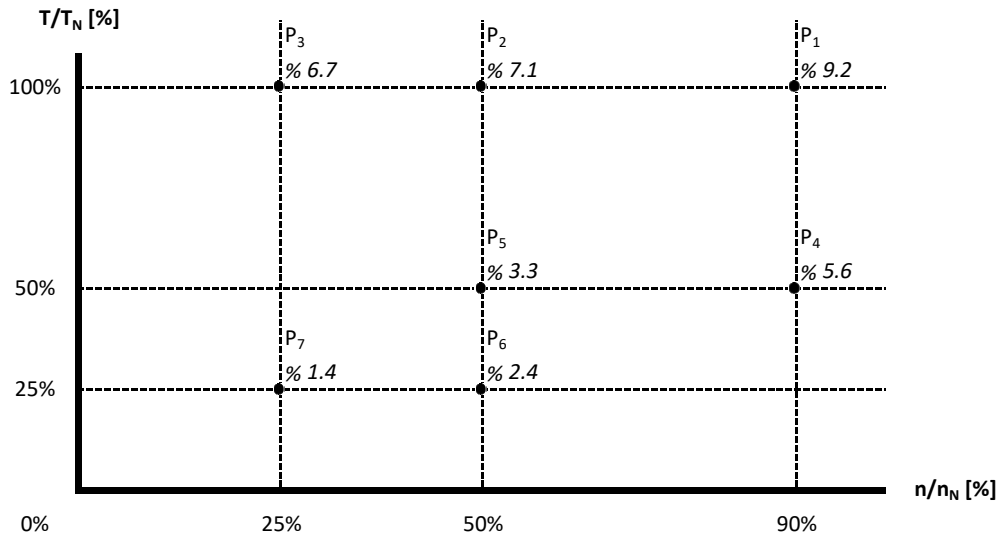

Manufactured and tested in accordance with IEC 60034

FR.AG.010 REV.NO: 04 REV.DATE: 01.01.2023

\*Technical data are subject to change! There may be discrepancies between calculated and rating plate values.

\*ELK Motor has right to change all the data without prior notice.

Motor Code : 3EL160M4C-FA-BA-000

### Torque and Current Curves Related to Speed

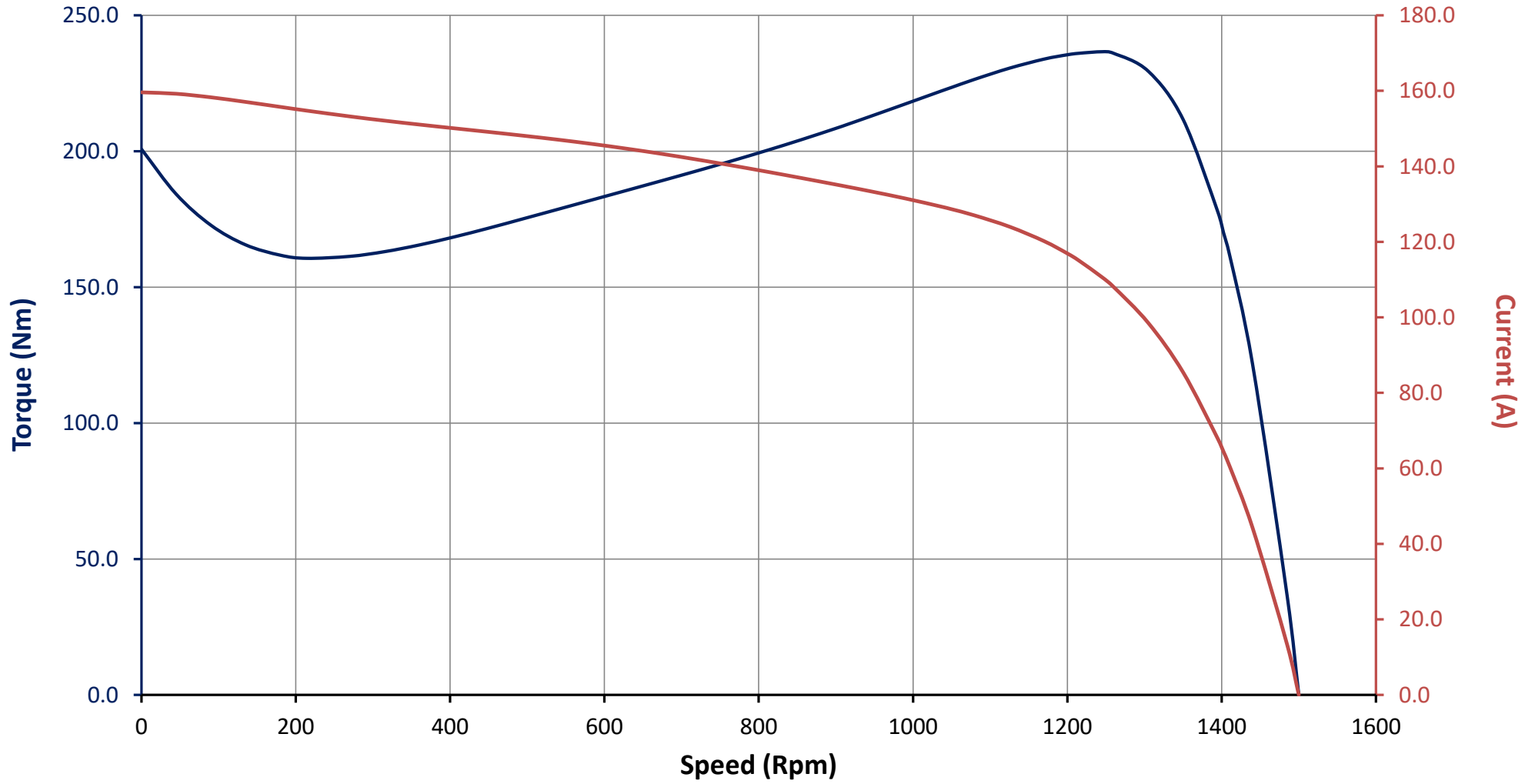

Motor Code : 3EL160M4C-FA-BA-000

### Performance Curves Related to Rated Output

