

Type : 4EG225S4D-PA-BA-000

Date : 01.01.2023

Power [kW]	: 37.0	Efficiency Class	: IE4
Input Voltage [V]	: 400	Duty Cycle	: S1
Connection Type [ $\Delta$ / Y]	: $\Delta$	Service Factor	: 1.25
Frequency [Hz]	: 50	Frame Size	: 225S
Pole Number	: 4	Weight [kg]	: 350
Nominal Speed [rpm]	: 1480	Insulation Class	: F [155°C]
Nominal Current [A]	: 65.0	Temperature Rise	: B [80°K]
Nominal Moment [Nm]	: 239	Protection Class	: IP55
Nominal Efficiency [ $\eta$ ]	: 95.2	Vibration Severity Grade	: A
Power Factor [ $\cos\phi$ ]	: 0.86	Method of Cooling	: IC411 (TEFC)
Locked Rotor Current [ $I_a/I_n$ ]	: 8.1	Direction of Rotation	: Bidirectional
Locked Rotor Torque [ $M_a/M_n$ ]	: 3.3	Balance	: Half Key
Breakdown Torque [ $M_k/M_n$ ]	: 3.3	Motor Thermal Protection	: PTC
Motor Color	: RAL 7031	Altitude Above Sea Level	: 1000m
Ambient Temperature	: -15°C / +40°C	Sound Pressure Level [dB(A)]	: 70

### ELECTRICAL DATA

$\Delta$ / Y	U [V]	f [Hz]	P [kW]	n [rpm]	I [A]	$\eta$ [%100]	$\eta$ [%75]	$\eta$ [%50]	$\cos\phi$	Cl
$\Delta$	400	50	37.0	1480	65.0	95.2	95.7	95.0	0.86	IE4
Y	690	50	37.0	1480	37.5	95.2	95.7	95.0	0.86	IE4
$\Delta$	460	60	37.0	1778	57.3	95.4	95.5	94.7	0.85	IE4
$\Delta$	460	60	42.9	1775	64.8	95.4	95.9	95.6	0.87	IE4

### MECHANICAL DATA

Moment of Inertia [ $\text{kgm}^2$ ]	: 0.44100
Bearing [DS / NS]	: 6313ZZ / 6213ZZ
Frame Material	: Cast Iron
Flange Type / Material	: B5 / Cast Iron
Cooling Fan Material	: Plastic
End Shield Material	: Cast Iron

### TERMINAL BOX

Terminal Box Material	: Cast Iron
Terminal Box Position	: Top
Terminal Box Cable Entry	: 2xM50x1.5
Terminal Box Blind Cap	: --
Contact Screw Thread	: M8

### MECHANICAL DIMENSIONS

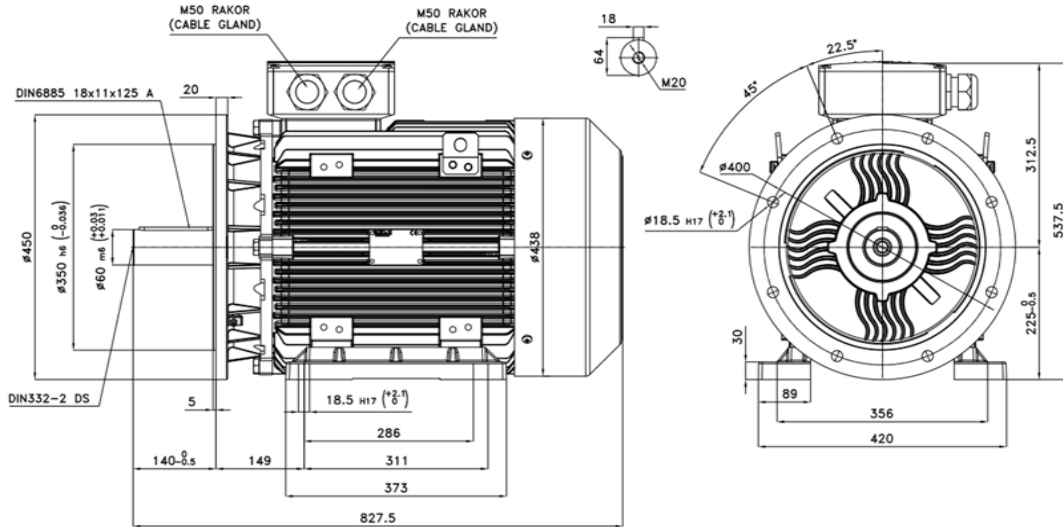

Manufactured and tested in accordance with IEC 60034

\*Technical data are subject to change! There may be discrepancies between calculated and rating plate values.

\*ELK Motor has right to change all the data without prior notice.

FR.AG.010 REV.NO: 04 REV.DATE: 01.01.2023



ELK MOTOR SAN. ve TİC. A.Ş.  
www.elkmotor.com.tr  
+90 (282) 726 92 94

## TECHNICAL DATASHEET ACCORDING TO COMMISSION REGULATION (EU) 2019/1781 THREE PHASE INDUCTION MOTOR - SQUIRREL CAGE

Type : 4EG225S4D-PA-BA-000

Date : 01.01.2023

### NAMEPLATE DATA

Power [kW]	: 37.0	Nominal Speed [rpm]	: 1480
Nominal Voltage [V]	: 400	Nominal Current [A]	: 65.0
Connection Type [ $\Delta$ / Y]	: $\Delta$	Nominal Moment [Nm]	: 239
Nominal Frequency [Hz]	: 50	Nominal Efficiency [ $\eta$ %]	: 95.2

### THE POWER LOSSES AT SEVEN OPERATING POINTS ACCORDING TO COMMISSION REGULATION (EU) 2019/1781

Operating Point Number	Speed $n/n_N$ [%]	Torque $T/T_N$ [%]	Relative Power Losses $P_L/P_N$ [%]	Efficiency $\eta$ [%]
P <sub>1</sub>	90	100	5.2	94.5
P <sub>2</sub>	50	100	3.9	92.8
P <sub>3</sub>	25	100	3.4	88.2
P <sub>4</sub>	90	50	3.3	93.2
P <sub>5</sub>	50	50	1.9	93.0
P <sub>6</sub>	50	25	1.4	90.2
P <sub>7</sub>	25	25	0.7	89.4

### MAP OF RELATIVE POWER LOSSES $P_L/P_N$ [%]

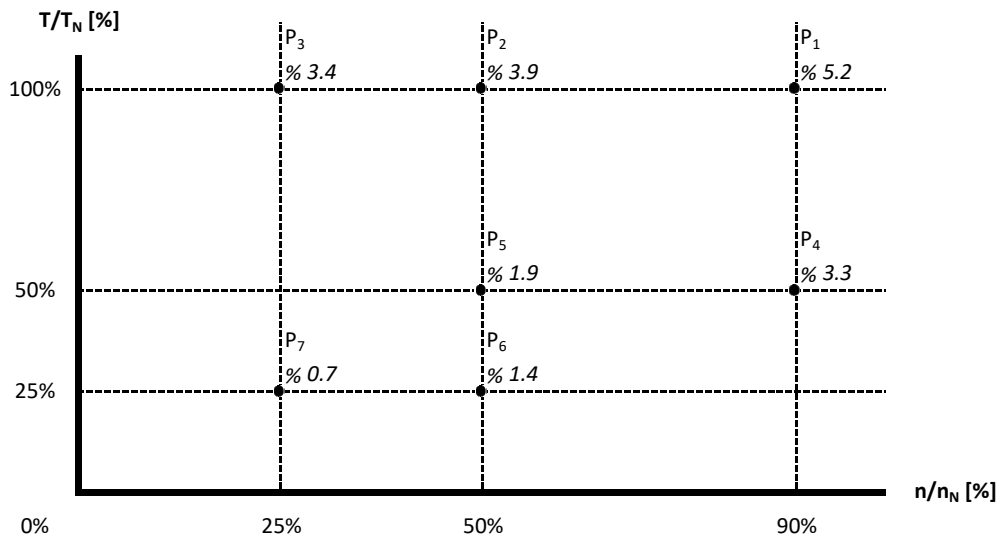

Manufactured and tested in accordance with IEC 60034

FR.AG.010 REV.NO: 04 REV.DATE: 01.01.2023

\*Technical data are subject to change! There may be discrepancies between calculated and rating plate values.

\*ELK Motor has right to change all the data without prior notice.

Motor Code : 4EG225S4D-PA-BA-000

### Torque and Current Curves Related to Speed

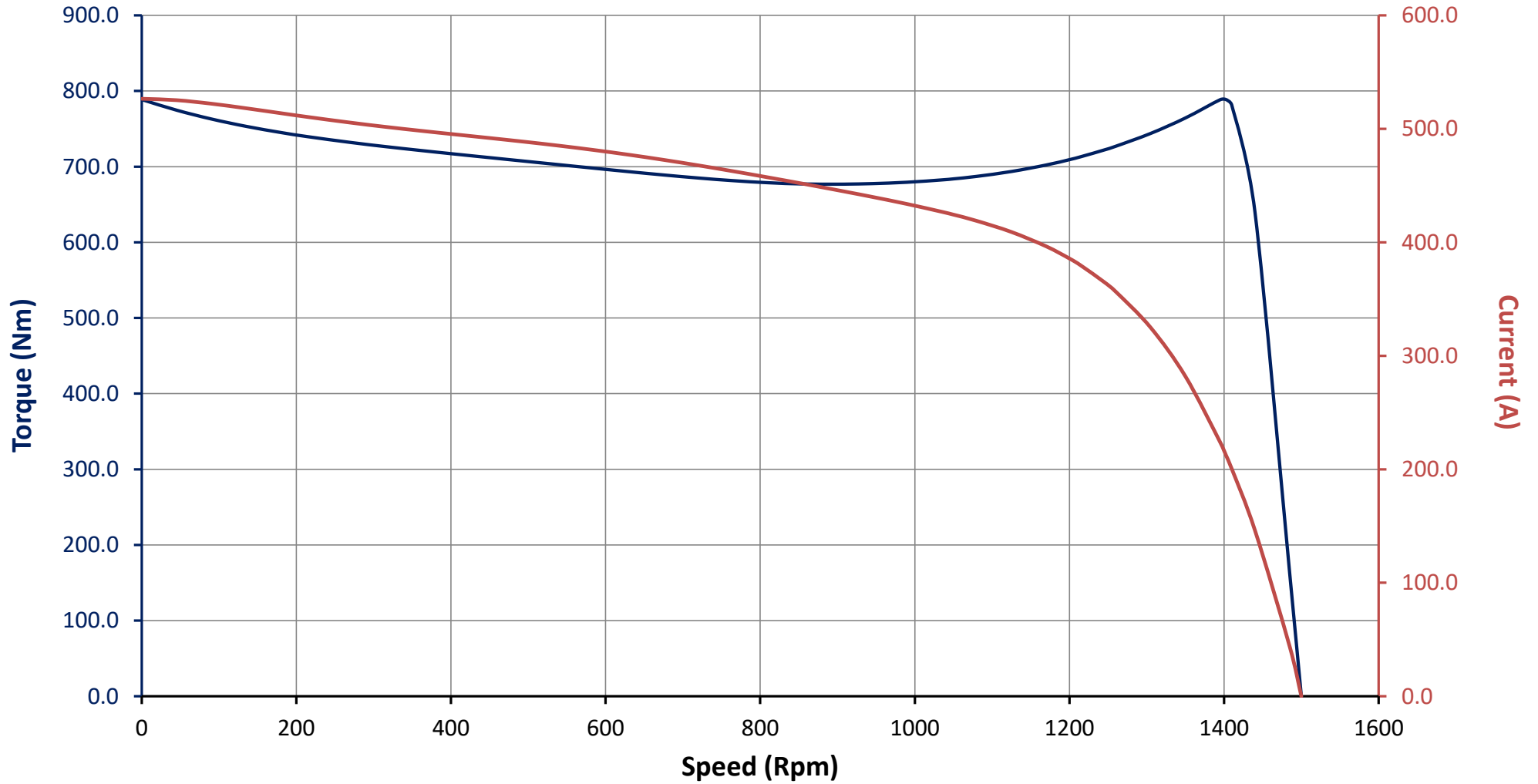

Motor Code : 4EG225S4D-PA-BA-000

### Performance Curves Related to Rated Output

