

Type : 3ED132M2D-PD-B0-000**Date** : 01.01.2023

| | | | |
|------------------------------|-----------------|----------------------------|-----------------|
| Power [kW] | : 11.0 | Efficiency Class | : IE3 |
| Input Voltage [V] | : 400 | Duty Cycle | : S1 |
| Connection Type [Δ / Y] | : Δ | Service Factor | : -- |
| Frequency [Hz] | : 50 | Frame Size | : 132M |
| Pole Number | : 2 | Weight [kg] | : 72.6 |
| Nominal Speed [rpm] | : 2940 | Insulation Class | : F [155°C] |
| Nominal Current [A] | : 19.8 | Temperature Rise | : B [80°K] |
| Nominal Moment [Nm] | : 35.7 | Protection Class | : IP55 |
| Nominal Efficiency [η] | : 91.2 | Vibration Severity Grade | : A |
| Power Factor [cosφ] | : 0.88 | Method of Cooling | : IC411 (TEFC) |
| Locked Rotor Current [Ia/In] | : 8.9 | Direction of Rotation | : Bidirectional |
| Locked Rotor Torque [Ma/Mn] | : 3.2 | Balance | : Half Key |
| Breakdown Torque [Mk/Mn] | : 4.4 | Motor Thermal Protection | : -- |
| Motor Color | : RAL 7031 | Altitude Above Sea Level | : 1000m |
| Ambient Temperature | : -15°C / +40°C | Sound Pressure Level [dBA] | : 69 |

ELECTRICAL DATA

| Δ / Y | U [V] | f [Hz] | P [kW] | n [rpm] | I [A] | η [%100] | η [%75] | η [%50] | Cosφ | Cl |
|-------|-------|--------|--------|---------|-------|----------|---------|---------|------|-----|
| Δ | 400 | 50 | 11.0 | 2940 | 19.8 | 91.2 | 91.9 | 91.5 | 0.88 | IE3 |
| Y | 690 | 50 | 11.0 | 2940 | 11.4 | 91.2 | 91.9 | 91.5 | 0.88 | IE3 |
| Δ | 460 | 60 | 11.0 | 3540 | 17.3 | 91.2 | 92.0 | 91.7 | 0.88 | IE3 |
| Δ | 460 | 60 | 12.8 | 3525 | 19.7 | 91.5 | 92.2 | 91.8 | 0.89 | IE3 |

MECHANICAL DATA

| | |
|---------------------------------------|-------------------|
| Moment of Inertia [kgm ²] | : 0.02290 |
| Bearing [DS / NS] | : 6208ZZ / 6208ZZ |
| Frame Material | : Cast Iron |
| Flange Type / Material | : B3 / Cast Iron |
| Cooling Fan Material | : Plastic |
| End Shield Material | : Cast Iron |

TERMINAL BOX

| | |
|--------------------------|-------------|
| Terminal Box Material | : Cast Iron |
| Terminal Box Position | : Top |
| Terminal Box Cable Entry | : M25x1.5 |
| Terminal Box Blind Cap | : M25x1.5 |
| Contact Screw Thread | : M5 |

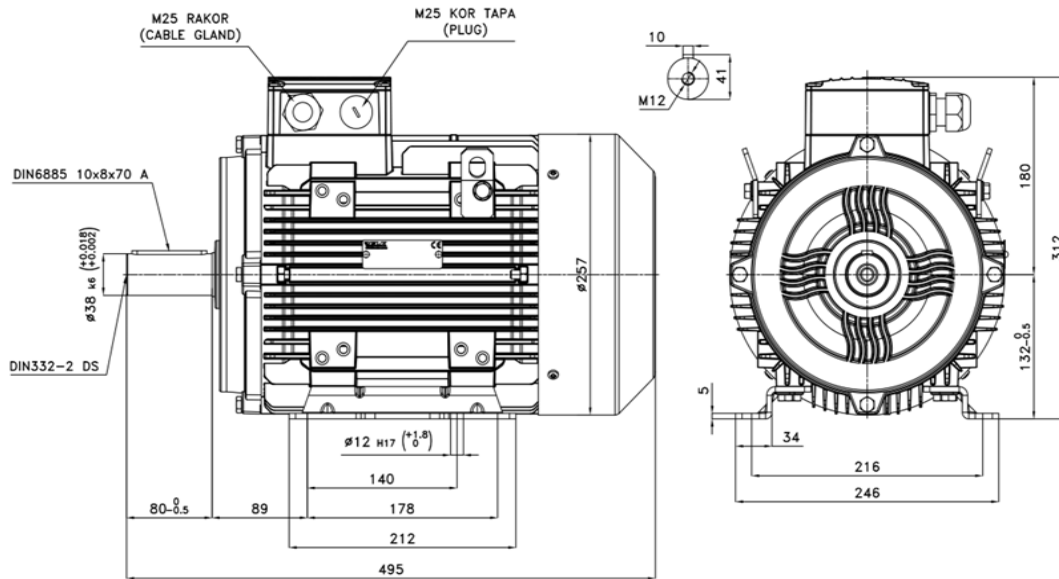
MECHANICAL DIMENSIONS

Manufactured and tested in accordance with IEC 60034

*Technical data are subject to change! There may be discrepancies between calculated and rating plate values.

*ELK Motor has right to change all the data without prior notice.

FR.AG.010 REV.NO: 04 REV.DATE: 01.01.2023



ELK MOTOR SAN. ve TİC. A.Ş.
www.elkmotor.com.tr
+90 (282) 726 92 94

TECHNICAL DATASHEET ACCORDING TO COMMISSION REGULATION (EU) 2019/1781 THREE PHASE INDUCTION MOTOR - SQUIRREL CAGE

Type : 3ED132M2D-PD-B0-000

Date : 01.01.2023

NAMEPLATE DATA

| | | | |
|---------------------------------|------------|--------------------------------|--------|
| Power [kW] | : 11.0 | Nominal Speed [rpm] | : 2940 |
| Nominal Voltage [V] | : 400 | Nominal Current [A] | : 19.8 |
| Connection Type [Δ / Y] | : Δ | Nominal Moment [Nm] | : 35.7 |
| Nominal Frequency [Hz] | : 50 | Nominal Efficiency [η %] | : 91.2 |

THE POWER LOSSES AT SEVEN OPERATING POINTS ACCORDING TO COMMISSION REGULATION (EU) 2019/1781

| Operating Point Number | Speed n/n_N [%] | Torque T/T_N [%] | Relative Power Losses P_L/P_N [%] | Efficiency η [%] |
|------------------------|-------------------|--------------------|-------------------------------------|-----------------------|
| P ₁ | 90 | 100 | 9.9 | 90.1 |
| P ₂ | 50 | 100 | 8.0 | 86.2 |
| P ₃ | 25 | 100 | 7.4 | 77.2 |
| P ₄ | 90 | 50 | 6.3 | 87.7 |
| P ₅ | 50 | 50 | 3.8 | 86.9 |
| P ₆ | 50 | 25 | 2.9 | 81.3 |
| P ₇ | 25 | 25 | 1.8 | 77.2 |

MAP OF RELATIVE POWER LOSSES P_L/P_N [%]

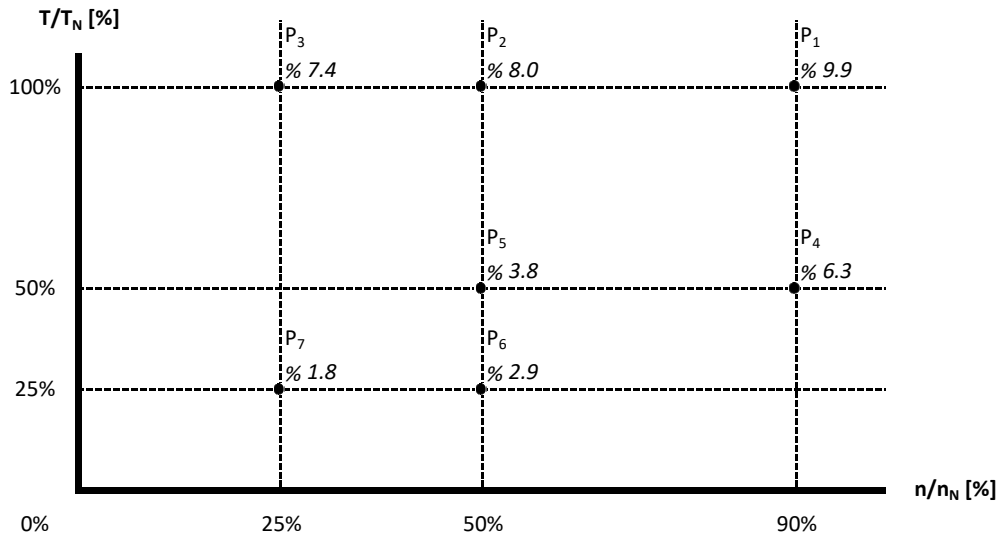

Manufactured and tested in accordance with IEC 60034

FR.AG.010 REV.NO: 04 REV.DATE: 01.01.2023

*Technical data are subject to change! There may be discrepancies between calculated and rating plate values.

*ELK Motor has right to change all the data without prior notice.

Motor Code : 3ED132M2D-PD-B0-000

Torque and Current Curves Related to Speed

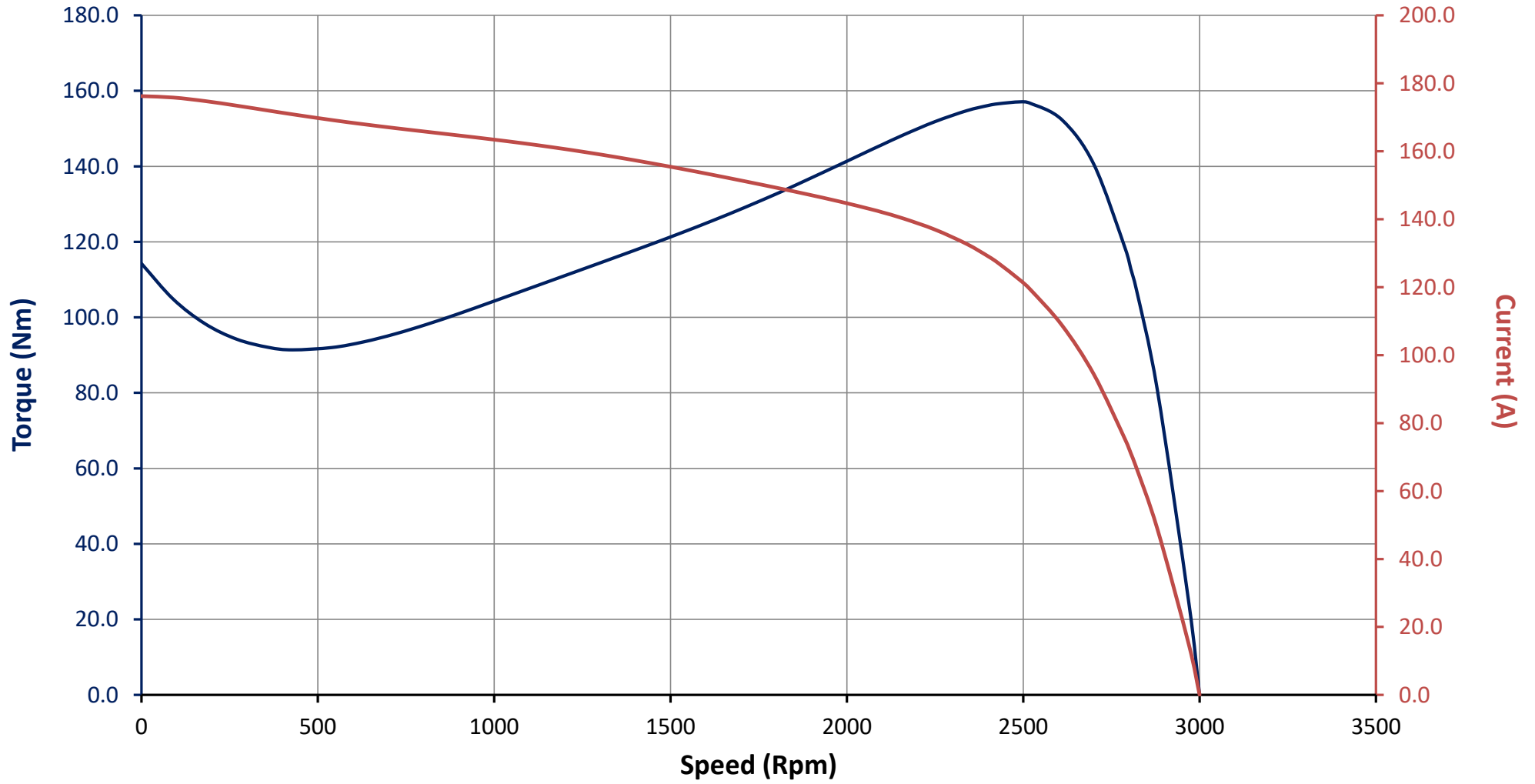

Motor Code : 3ED132M2D-PD-B0-000

Performance Curves Related to Rated Output

