

Type : 2EL071M4B-PD-A0-000

Date : 01.01.2023

Power [kW]	: 0.25	Efficiency Class	: IE2
Input Voltage [V]	: 400	Duty Cycle	: S1
Connection Type [Δ / Y]	: Y	Service Factor	: 1.15
Frequency [Hz]	: 50	Frame Size	: 071M
Pole Number	: 4	Weight [kg]	: 6.30
Nominal Speed [rpm]	: 1425	Insulation Class	: F [155°C]
Nominal Current [A]	: 0.71	Temperature Rise	: B [80°K]
Nominal Moment [Nm]	: 1.68	Protection Class	: IP55
Nominal Efficiency [η]	: 74.0	Vibration Severity Grade	: A
Power Factor [cosφ]	: 0.69	Method of Cooling	: IC411 (TEFC)
Locked Rotor Current [Ia/In]	: 4.4	Direction of Rotation	: Bidirectional
Locked Rotor Torque [Ma/Mn]	: 2.0	Balance	: Half Key
Breakdown Torque [Mk/Mn]	: 3.0	Motor Thermal Protection	: --
Motor Color	: RAL 7031	Altitude Above Sea Level	: 1000m
Ambient Temperature	: -15°C / +40°C	Sound Pressure Level [dBA]	: 46

### ELECTRICAL DATA

Δ / Y	U [V]	f [Hz]	P [kW]	n [rpm]	I [A]	η [%100]	η [%75]	η [%50]	Cosφ	Cl
Δ	230	50	0.25	1425	1.23	74.0	73.5	70.5	0.69	IE2
Y	400	50	0.25	1425	0.71	74.0	73.5	70.5	0.69	IE2
Y	460	60	0.25	1730	0.64	74.6	74.2	71.4	0.66	IE2
Y	460	60	0.29	1720	0.70	75.8	75.0	71.0	0.69	IE2

### MECHANICAL DATA

Moment of Inertia [kgm <sup>2</sup> ]	: 0.00067
Bearing [DS / NS]	: 6202ZZ / 6202ZZ
Frame Material	: Aluminum
Flange Type / Material	: B3 / Aluminum
Cooling Fan Material	: Plastic
End Shield Material	: Aluminum

### TERMINAL BOX

Terminal Box Material	: Aluminum
Terminal Box Position	: Top
Terminal Box Cable Entry	: M20x1.5
Terminal Box Blind Cap	: M16x1.5
Contact Screw Thread	: M4

### MECHANICAL DIMENSIONS

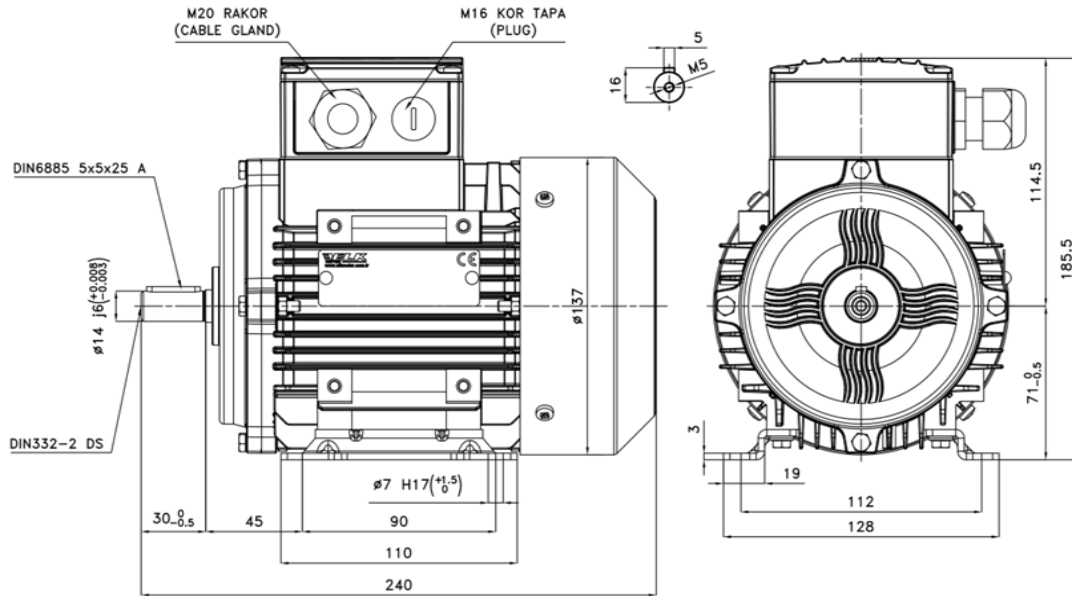

Manufactured and tested in accordance with IEC 60034

\*Technical data are subject to change! There may be discrepancies between calculated and rating plate values.

\*ELK Motor has right to change all the data without prior notice.

FR.AG.010 REV.NO: 04 REV.DATE: 01.01.2023



ELK MOTOR SAN. ve TİC. A.Ş.  
www.elkmotor.com.tr  
+90 (282) 726 92 94

## TECHNICAL DATASHEET ACCORDING TO COMMISSION REGULATION (EU) 2019/1781 THREE PHASE INDUCTION MOTOR - SQUIRREL CAGE

Type : 2EL071M4B-PD-A0-000

Date : 01.01.2023

### NAMEPLATE DATA

Power [kW]	: 0.25	Nominal Speed [rpm]	: 1425
Nominal Voltage [V]	: 400	Nominal Current [A]	: 0.71
Connection Type [ $\Delta$ / Y]	: Y	Nominal Moment [Nm]	: 1.68
Nominal Frequency [Hz]	: 50	Nominal Efficiency [ $\eta$ %]	: 74.0

### THE POWER LOSSES AT SEVEN OPERATING POINTS ACCORDING TO COMMISSION REGULATION (EU) 2019/1781

Operating Point Number	Speed $n/n_N$ [%]	Torque $T/T_N$ [%]	Relative Power Losses $P_L/P_N$ [%]	Efficiency $\eta$ [%]
P <sub>1</sub>	90	100	34.0	72.6
P <sub>2</sub>	50	100	28.8	63.5
P <sub>3</sub>	25	100	29.3	46.2
P <sub>4</sub>	90	50	24.8	64.6
P <sub>5</sub>	50	50	15.6	61.8
P <sub>6</sub>	50	25	14.1	46.8
P <sub>7</sub>	25	25	8.9	41.7

### MAP OF RELATIVE POWER LOSSES $P_L/P_N$ [%]

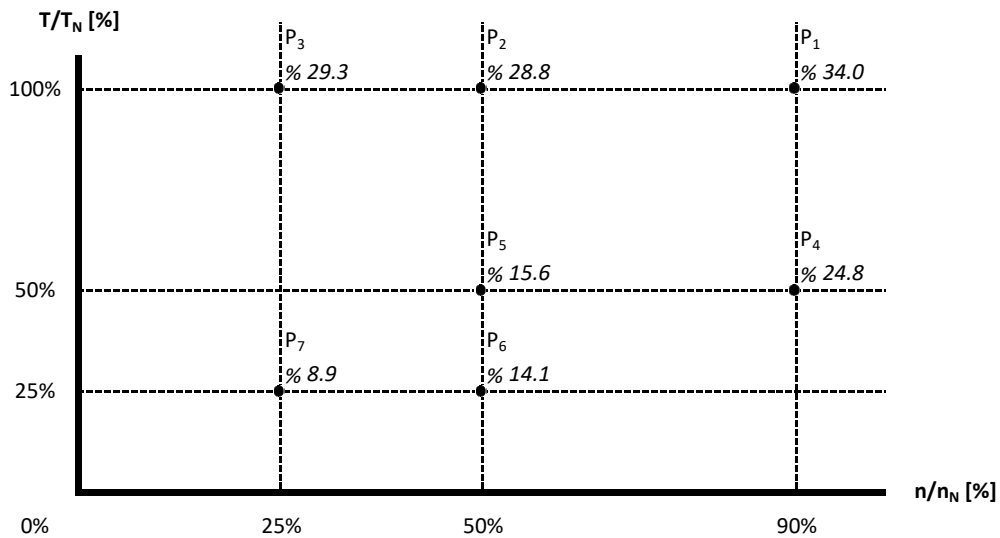

Manufactured and tested in accordance with IEC 60034

FR.AG.010 REV.NO: 04 REV.DATE: 01.01.2023

\*Technical data are subject to change! There may be discrepancies between calculated and rating plate values.

\*ELK Motor has right to change all the data without prior notice.

Motor Code : 2EL071M4B-PD-A0-000

Torque and Current Curves Related to Speed

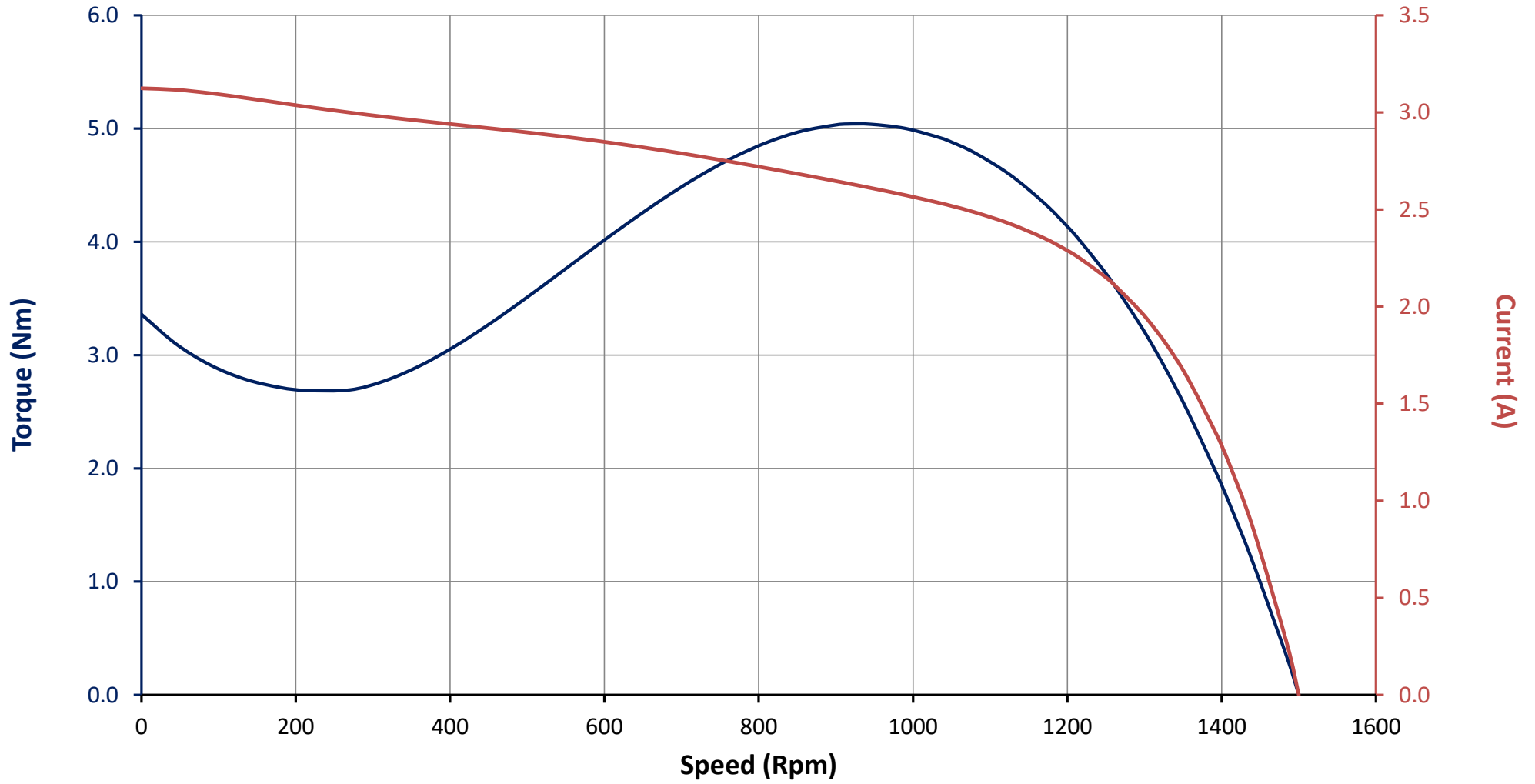

Motor Code : 2EL071M4B-PD-A0-000

### Performance Curves Related to Rated Output

